

TOP VIEW

BOTTOM VIEW

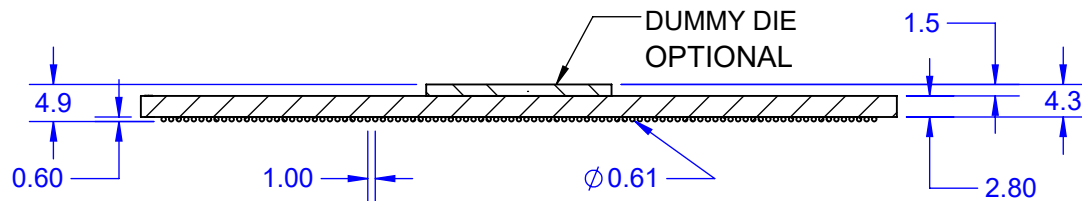
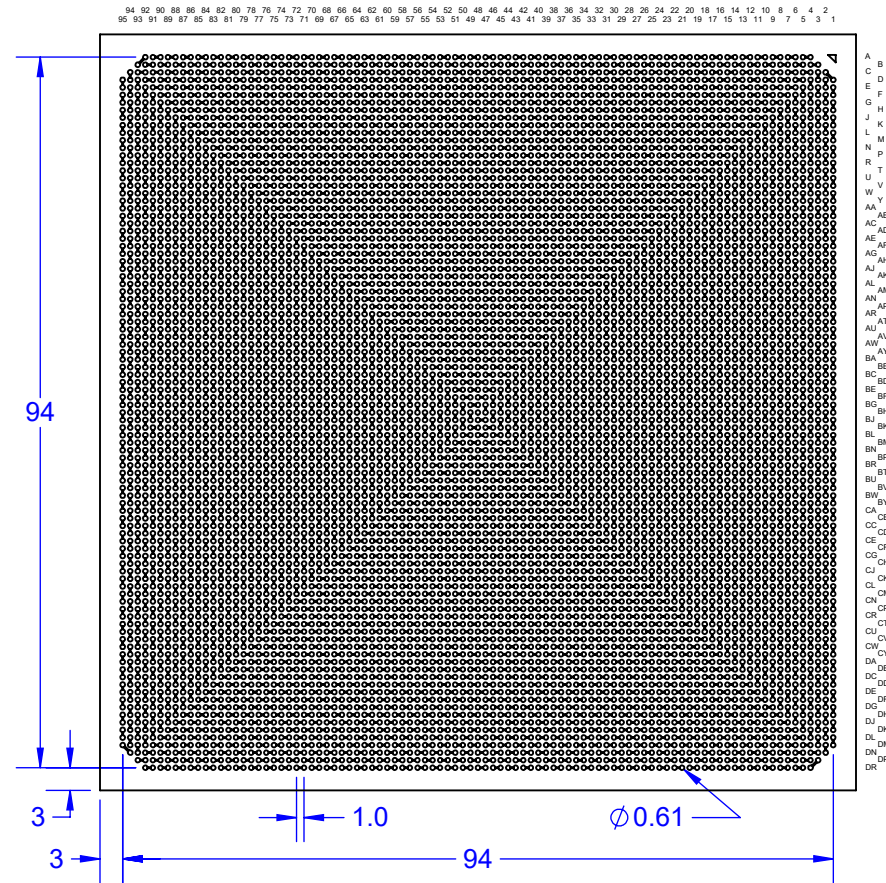
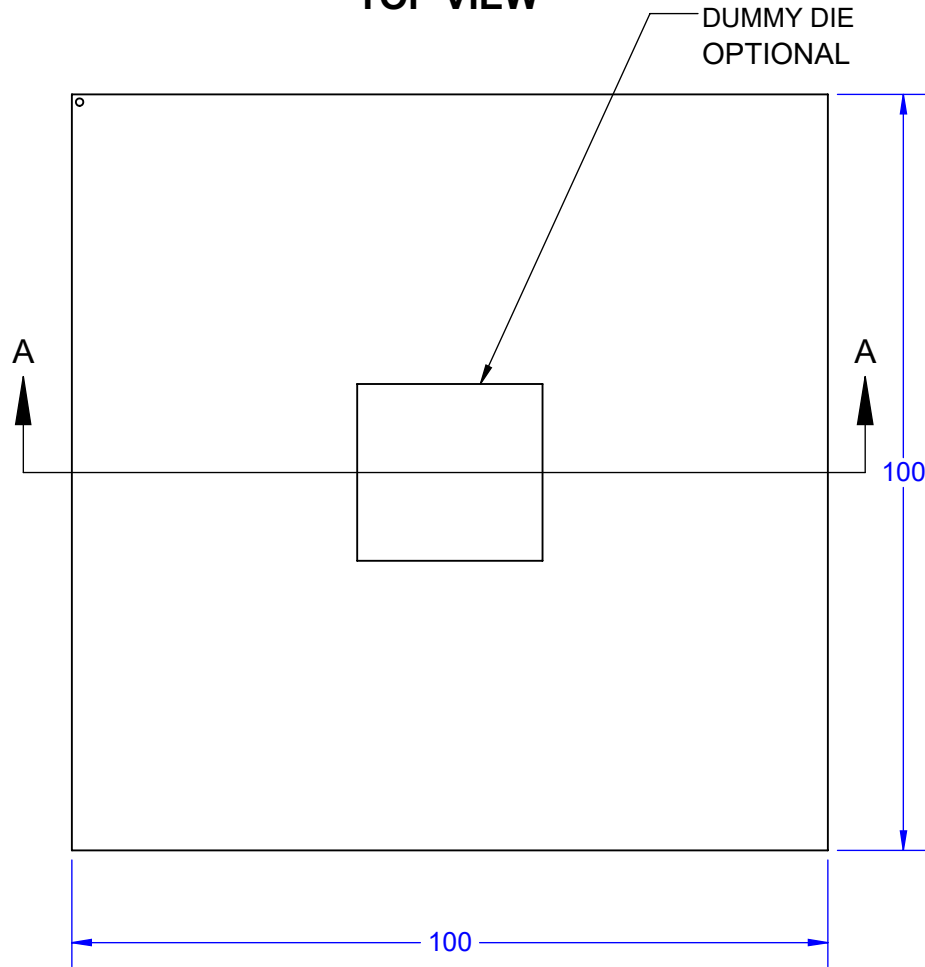

SECTION A-A

Notes: (Unless Otherwise Specified).

- 1) ALL DIMENSIONS ARE IN MM.
- 2) SOLDER BALL ALLOY: SEE PART NUMBER TABLE.
- 3) BALL DIAMETER (BEFORE REFLOW): $\phi 0.61\text{mm}$ (24 MIL).
- 4) SOLDER MASK DEFINED PAD OPENING: 0.50mm (19.7 MIL).
- 5) PAD Cu DIAMETER: 0.635mm (25 MIL).
- 6) SUBSTRATE MATERIAL: ORGANIC.
- 7) DUMMY DIE Si (SILICON) $24.5 \times 23.4\text{mm}$ (OPTIONAL).
- 8) DAISY CHAIN PATTERN (SEE PAGE 2).
- 9) MSL-3 RECOMMENDED BAKING 24 HOURS @ 125°C TO REMOVE MOISTURE PRIOR SOLDERING TO PC BOARD.

PART NUMBER TABLE				
PART NUMBER	BALL ALLOY	BALL ALLOY	RoHS	Si DIE
LPGA8989T1.0C-DC959D	Sn96.5/Ag3.0/Cu0.5	SAC305	YES	YES
LPGA8989T1.0-DC959D	Sn63/Pb37	Sn63	NO	YES

APPROVALS	DATE				
DRAWN T. Au	6/15/2022				
ENG M. Hart	6/15/2022	TITLE LPGA8989T1.0-DC959D DAISY CHAIN DUMMY			
MFG		SCALE 1:1	SIZE A	DRAWING NO. 519591	REV A
QA		DO NOT SCALE DRAWING			SHEET 1 OF 5
CUST					
REVISED					

BALL VIEW

94 92 90 88 86 84 82 80 78 76 74 72 70 68 66 64 62 60 58 56 54 52 50 48 46 44 42 40 38 36 34 32 30 28 26 24 22 20 18 16 14 12 10 8 6 4 2
 95 93 91 89 87 85 83 81 79 77 75 73 71 69 67 65 63 61 59 57 55 53 51 49 47 45 43 41 39 37 35 33 31 29 27 25 23 21 19 17 15 13 11 9 7 5 3 1

A
B
C
D
E
F
G
H
J
K
L
M
N
P
R
T
U
V
W
Y
AA
AB
AC
AD
AE
AF
AG
AH
AJ
AK
AL
AM
AN
AP
AR
AT
AU
AV
AW
AY
BA
BB
BC
BD
BE
BF
BG
BH
BJ
BK
BL
BM
BN
BP
BR
BT
BU
BV
BW
BY
CA
CB
CC
CD
CE
CF
CG
CH
CJ
CK
CL
CM
CN
CP
CR
CT
CU
CV
CW
CY
DA
DB
DC
DD
DE
DF
DG
DH
DJ
DK
DL
DM
DN
DP
DR

PIN A1



TITLE			
LBGA8989T1.0-DC959D DAISY CHAIN DUMMY			
SCALE	SIZE	DRAWING NO.	REV
1.75:1	A	519591	A
DO NOT SCALE DRAWING			SHEET 2 OF 5

BOTTOM SIDE (TOP X-RAY VIEW)

PIN A1

2 4 6 8 10 12 14 16 18 20 22 24 26 28 30 32 34 36 38 40 42 44 46 48 50 52 54 56 58 60 62 64 66 68 70 72 74 76 78 80 82 84 86 88 90 92 94
 1 3 5 7 9 11 13 15 17 19 21 23 25 27 29 31 33 35 37 39 41 43 45 47 49 51 53 55 57 59 61 63 65 67 69 71 73 75 77 79 81 83 85 87 89 91 93 95

A
B
C
D
E
F
G
H
J
K
L
M
N
P
R
T
U
V
W
Y
AA
AB
AC
AD
AE
AF
AG
AH
AJ
AK
AL
AM
AN
AP
AR
AT
AU
AV
AW
AY
BA
BB
BC
BD
BE
BF
BG
BH
BJ
BK
BL
BM
BN
BP
BR
BT
BU
BV
BW
BY
CA
CB
CC
CD
CE
CF
CG
CH
CJ
CK
CL
CM
CN
CP
CR
CT
CU
CV
CW
CY
DA
DB
DC
DD
DE
DF
DG
DH
DJ
DK
DL
DM
DN
DP
DR

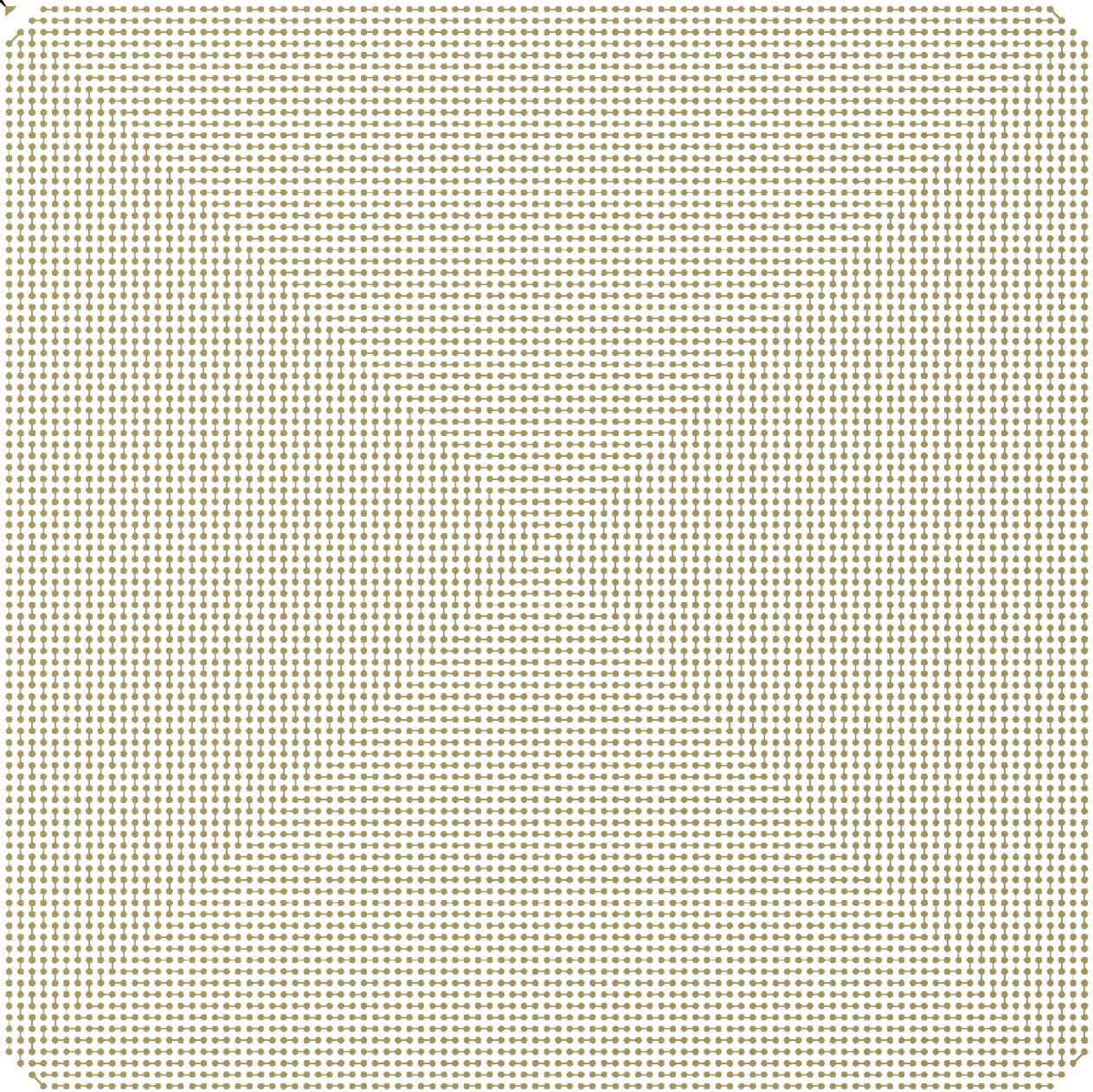

TopLine®			
TITLE LBG8989T1.0-DC959D DAISY CHAIN DUMMY			
SCALE 1.75:1	SIZE A	DRAWING NO. 519591	REV A
DO NOT SCALE DRAWING		SHEET 3 OF 5	

MODEL

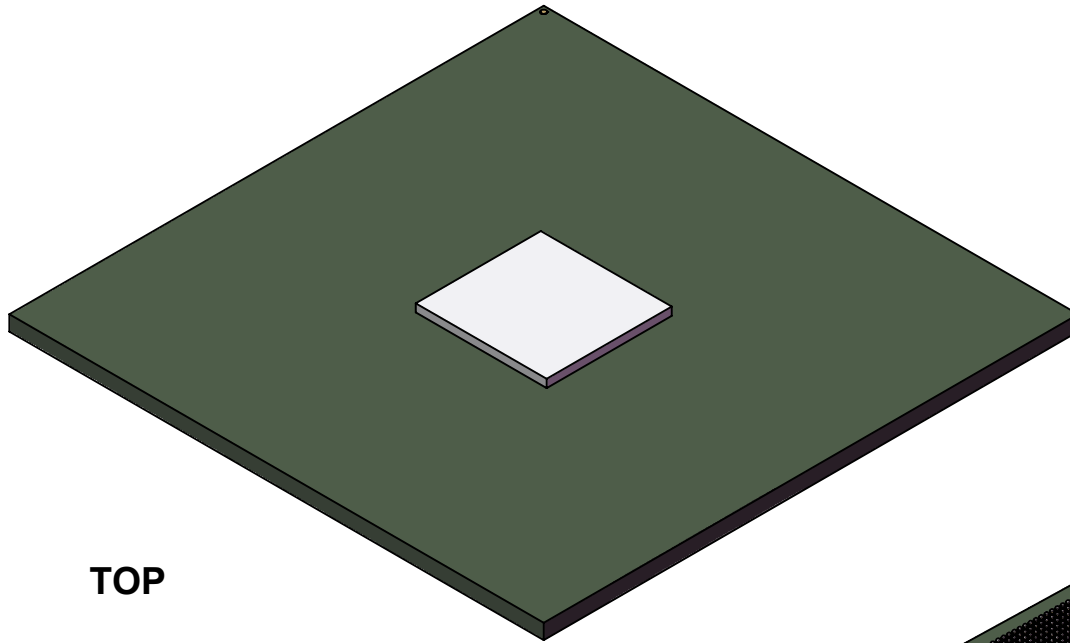

TOP

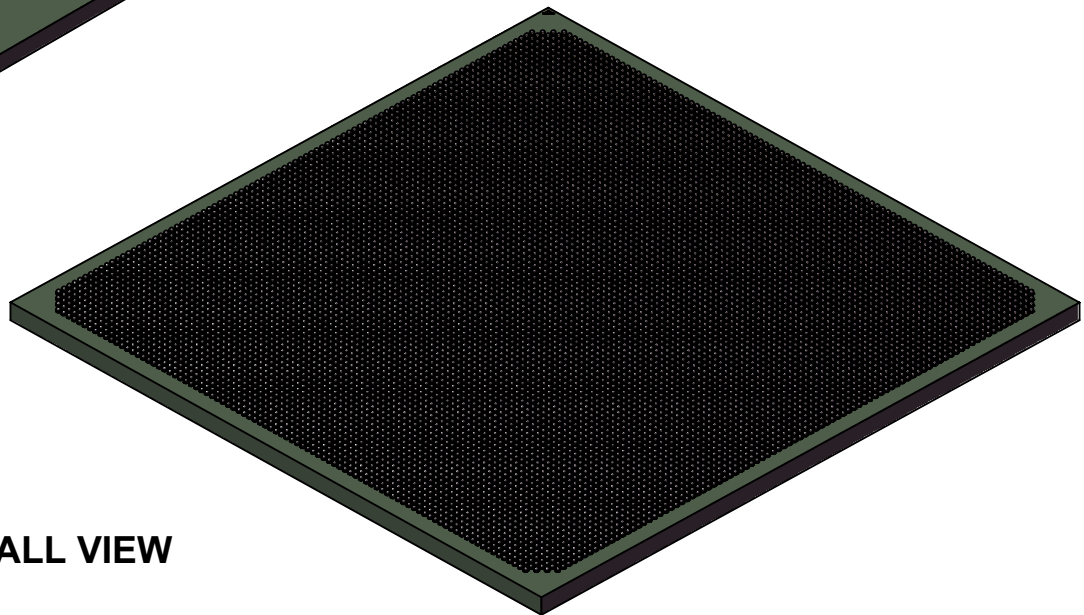

BALL VIEW

TopLine[®]

TITLE LPGA8989T1.0-DC959D
DAISY CHAIN DUMMY

SCALE 1:1	SIZE A	DRAWING NO. 519591	REV A
--------------	-----------	-----------------------	----------

DO NOT SCALE DRAWING

SHEET 4 OF 5

BOTTOM SOLDER MASK (RIGHT READING)

94 92 90 88 86 84 82 80 78 76 74 72 70 68 66 64 62 60 58 56 54 52 50 48 46 44 42 40 38 36 34 32 30 28 26 24 22 20 18 16 14 12 10 8 6 4 2
95 93 91 89 87 85 83 81 79 77 75 73 71 69 67 65 63 61 59 57 55 53 51 49 47 45 43 41 39 37 35 33 31 29 27 25 23 21 19 17 15 13 11 9 7 5 3 1

A
B
C
D
E
F
G
H
J
K
L
M
N
P
R
T
U
V
W
Y
AA
AC
AD
AE
AF
AG
AH
AJ
AK
AL
AM
AN
AP
AR
AT
AU
AV
AW
AY
BA
BB
BC
BD
BE
BF
BG
BH
BJ
BK
BL
BM
BN
BP
BR
BT
BU
BV
BW
BY
CA
CB
CC
CD
CE
CF
CG
CH
CJ
CK
CL
CM
CN
CP
CR
CT
CU
CV
CW
CY
DA
DB
DC
DD
DE
DF
DG
DH
DJ
DK
DL
DM
DN
DP
DR

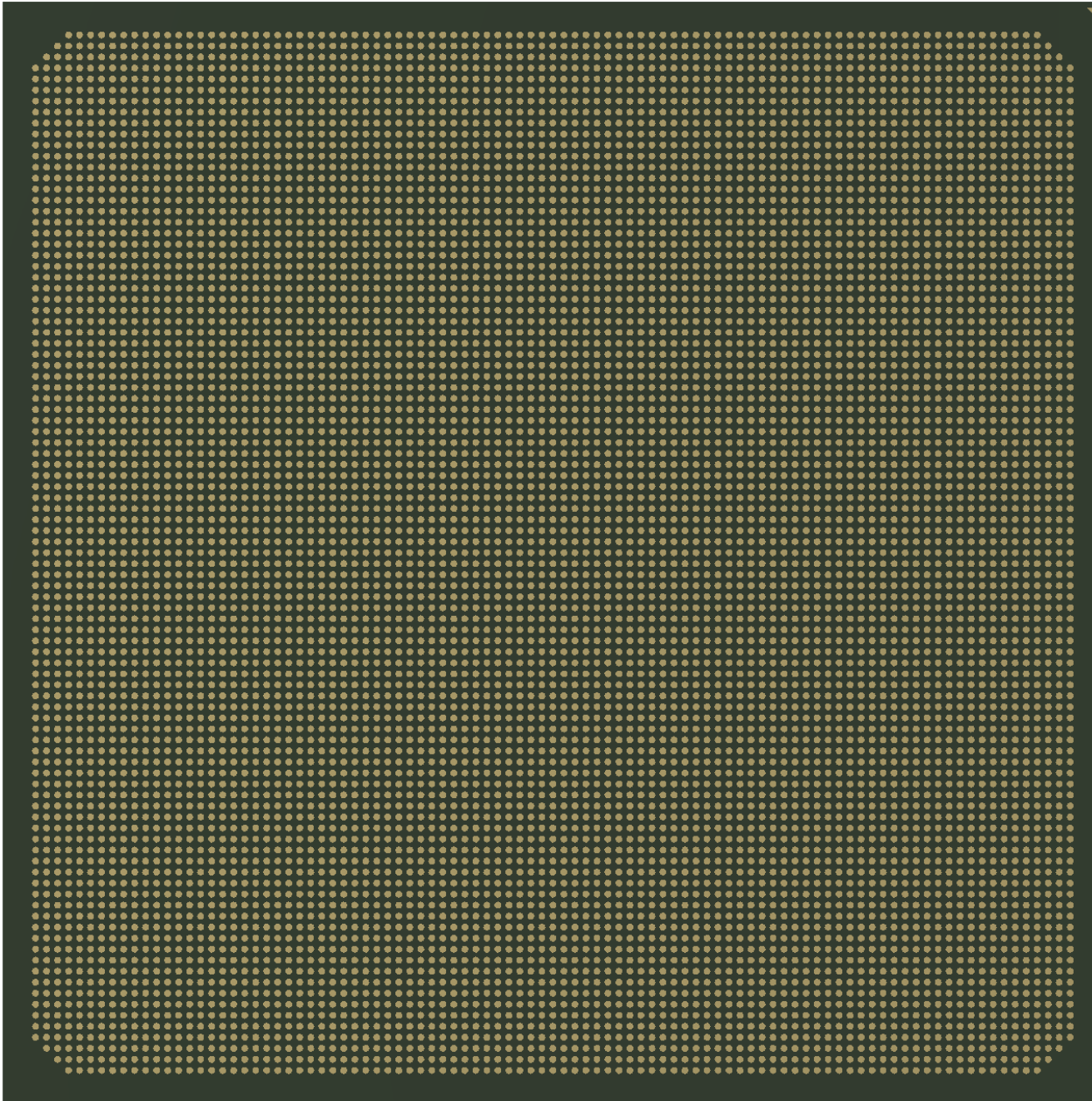

TopLine®			
TITLE LPGA8989T1.0-DC959D DAISY CHAIN DUMMY			
SCALE 1.75:1	SIZE A	DRAWING NO. 519591	REV A
DO NOT SCALE DRAWING			SHEET 5 OF 5